

ICS 21.060.10

J 13



**NATIONAL STANDARD OF THE PEOPLE'S REPUBLIC
OF CHINA**

中华人民共和国国家标准

GB/T 882-2008

Replace GB/T 882-1986

Clevis pin with head

销 轴

(ISO 2341: 1986, MOD)

Issued on Aug 25, 2008

Implemented on Feb 01, 2009

Issued by General Administration of Quality Supervision, Inspection and Quarantine
of the People's Republic of China

Standardization Administration of the People's Republic of China (SAC)

Clevis pin with head

1 Scope

This standard specifies the characteristics of clevis pins with head, with nominal diameter, d , from 3mm to 100mm inclusive.

2 Normative references

The articles contained in the following documents have become this standard when they are quoted herein. For the dated documents so quoted, all the modifications (excluding corrections) or revisions made thereafter shall not be applicable to this Standard. For the undated documents so quoted, the latest editions shall be applicable to this Standard.

GB/T 90.1 Fasteners—Acceptance inspection (GB/T 90.1-2002, ISO 3269: 2000, IDT)

GB/T 90.2 Fasteners—Marking and packaging

GB/T 91 Split pins (GB/T 91-2000, eqv ISO 1234: 1997)

GB/T 1237-2000 Fasteners- Marking Method (eqv ISO 8991:1986)

GB/T 5267.1 Fasteners—Electroplated coatings (GB/T 5267.1-2002, ISO 4042: 1999, IDT)

GB/T 11376-1997 Phosphate conversion coatings for metals (eqv ISO 9717: 1990)

3 Dimensions

See Figure 1 and Table 1.

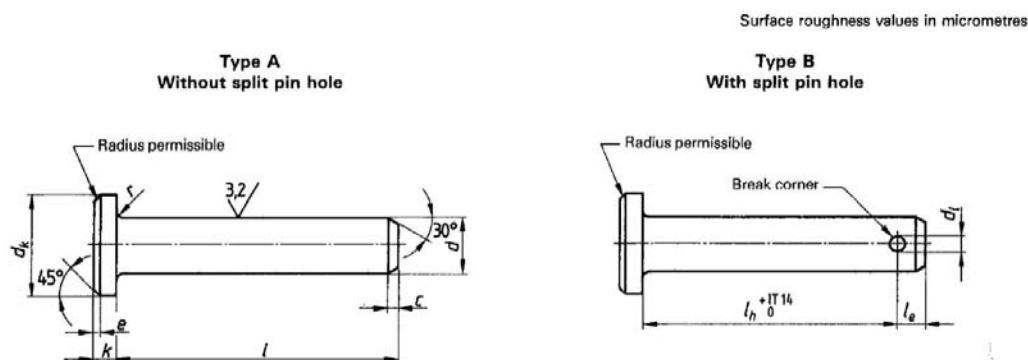

NOTES

- 1 Other dimensions, angles and surface roughness value, see type A.
- 2 In cases where a distance l_h which is not in accordance with $l - l_e$ is necessary, this distance should be fixed in the designation (see clause 5), but in no case may the values for l_h be smaller than those given in the table.

NOTE — For railway applications and in cases where the split pins are subjected to alternating transverse forces, it is recommended that the next larger split pin and corresponding hole diameter to that specified be used.

Figure 1

完整版本请在线下单

或咨询：

TEL: 400-678-1309

QQ: 19315219

Email: info@lancarver.com

<http://www.lancarver.com>

线下付款方式：

1. 对公账户：

单位名称：北京文心雕语翻译有限公司

开户行：中国工商银行北京清河镇支行

账 号：0200 1486 0900 0006 131

2. 支付宝账户：info@lancarver.com

注：付款成功后，请预留电邮，完整版本将在一个工作日内通过电子 PDF 或 Word 形式发送至您的预留邮箱，如需索取发票，下单成功后的三个工作日内安排开具并寄出，预祝合作愉快！
