

UDC 621.882



NATIONAL STANDARD OF THE PEOPLE'S REPUBLIC
OF CHINA

中华人民共和国国家标准

GB 825-1988

Replace GB 825-1976

Eyebolts

吊 环 螺 钉

Issued on Apr 04, 1988

Implemented on Jan 01, 1989

Issued by State Bureau of Machine-Building Industry

Eyebolts

1 Subject Contents and Scope of Application

This Standard specifies the eyebolts for lifting appliance, etc. with specification of M8 to M100×6.

2 Cited Standard

GB 2 Fasteners—Ends of parts with external thread

GB 699 Quality carbon structural steels

GB 196 General purpose metric screw threads—Basic dimensions

GB 197 General purpose metric screw threads—Tolerances

GB 230 Metallic materials—Rockwell hardness test

GB 5267 Electroplated coatings on threaded fasteners

GB 1237 Designation system for fasteners

GB 90 Acceptance inspection, marking and packaging of fasteners

YB 27 Steel-Determination of grain size method

3 Type, Dimension and Maximum Lifting Weight

3.1 Type sees Figure 1.

3.2 Dimension sees Table 1.

3.3 Maximum lifting weight sees Table 2.

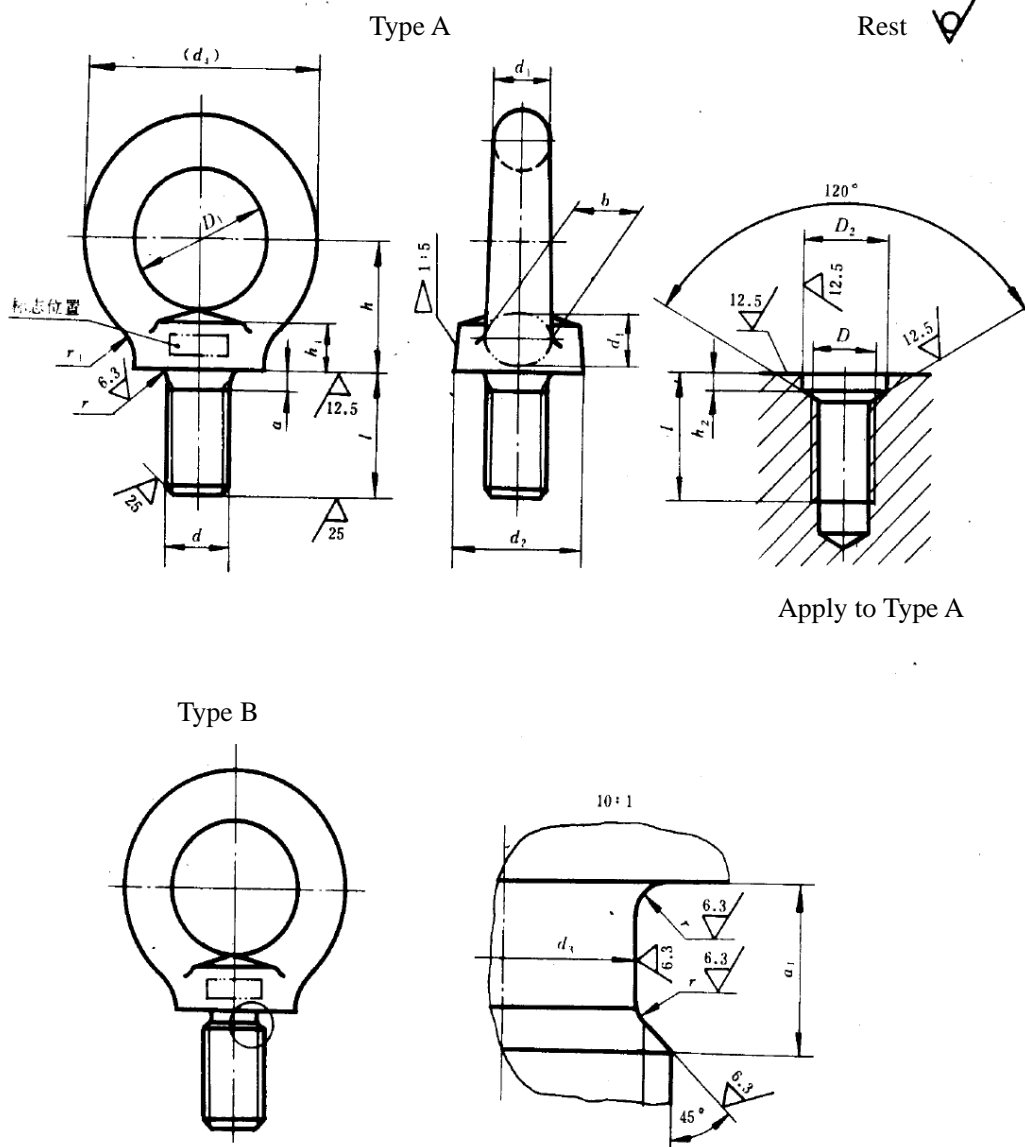

End chamfer or rounding is in accordance with GB 2;

Type A rod diameter without threaded parts approximate pitch diameter of thread or equal to major diameter of thread.

Figure 1



北京文心雕语翻译有限公司
Beijing Lancarver Translation Inc.

完整版本请在线下单

或咨询：

TEL: 400-678-1309

QQ: 19315219

Email: info@lancarver.com

<http://www.lancarver.com>

线下付款方式：

1. 对公账户：

单位名称：北京文心雕语翻译有限公司

开户行：中国工商银行北京清河镇支行

账 号：0200 1486 0900 0006 131

2. 支付宝账户：info@lancarver.com

注：付款成功后，请预留电邮，完整版本将在一个工作日内通过电子 PDF 或 Word 形式发送至您的预留邮箱，如需索取发票，下单成功后的三个工作日内安排开具并寄出，预祝合作愉快！



银联特约商户